

Lectrotab Retrofit Instructions (Replacing Bennett Standard System)

Old



**Standard Bennett
Actuator (A1101A)**

New



**Standard Lectrotab
Actuator (A-BK)**

Removing Old Bennett Actuator

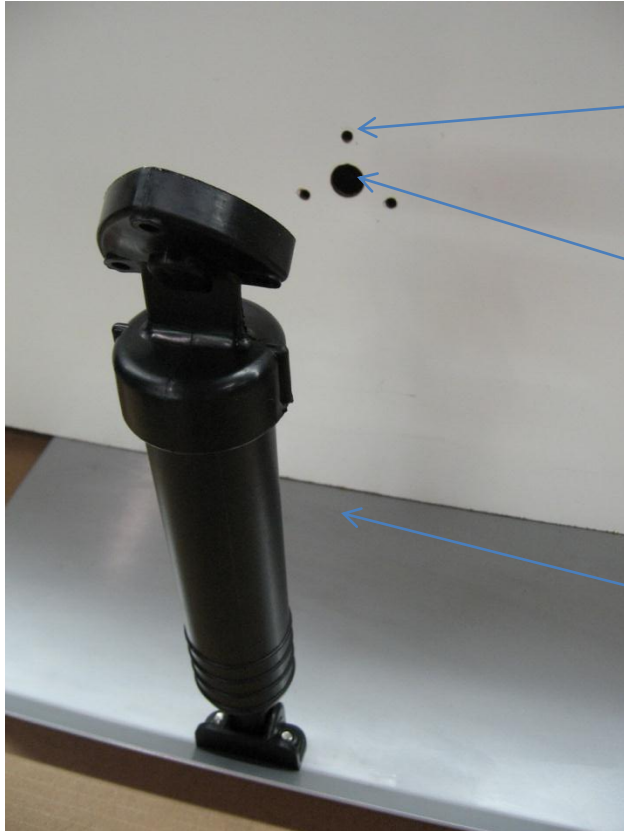

1) Remove the 3 upper mounting bracket screws (#14 x 1-1/2").

2) Remove and dispose of the hydraulic tubing.

4) Remove and dispose of the old Bennett actuator.

3) Remove the actuator by driving out the lower bracket pin. KEEP the lower bracket and pin. The Bennett pin and lower bracket will be used to mount the Lectrotab actuator.

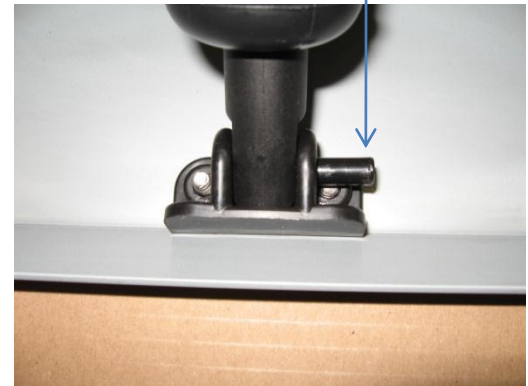

Installing New Lectrotab Actuator

1) Innermost holes match the Bennett upper mounting bracket hole pattern. Punch or drill out innermost holes on Lectrotab upper mounting bracket.

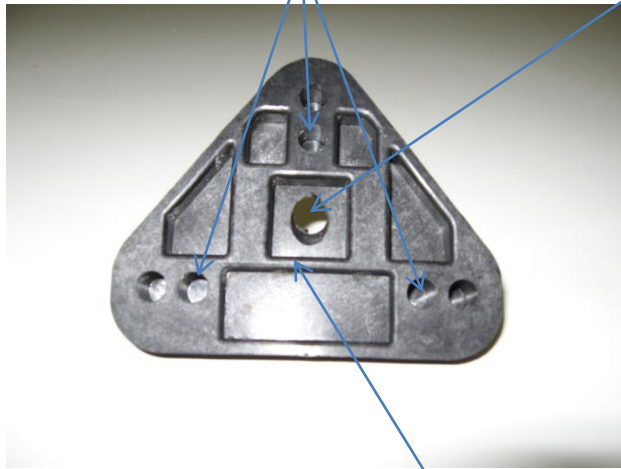

2) Insert two conductor cable with vent tube through upper bracket center hole.

3) Tighten upper bracket bolt snug against bracket so actuator rotates freely. Do not over-tighten.

4) Next insert two conductor cable with vent tube through old Bennett hydraulic tube hole in transom.



5) Lastly, fill the upper bracket rear cavity, face, cable and transom holes with a 3M 5200 or similar sealant, and tighten upper bracket with screws (#14 x 1-1/2") to transom.

Note:

A-BK actuator has 6' (1.8m) cable and connects to 4 conductor interconnect cable (W4-cable length).
A-BK-13 actuator has 23' (7m) cable length and
A-BK-24 actuator has 28' (8.5m) cable length which connects directly to control switch.

Installing New Lectrotab Actuator

IMPORTANT: For tabs mounted under the hull bottom in a pocket, there must be a ¼” minimum gap clearance between the top surface of the tab plate and hull bottom (clearance is required to allow actuator ball screw to spin freely in fully retracted position). Spacers may be used under the actuator lower mounting bracket to provide the clearance gap. For vertical actuator applications, spacers may be required on the side or bottom of the actuator lower bracket for actuator and tab clearance.

- 6) Insert Lectrotab ram in existing Bennett lower bracket. Retrieve existing Bennett lower bracket pin and drive through bracket .



Actuator mounting is complete.





Installing New Lectrotab Control

- Discard Bennett hydraulic pump, wiring and keypad control.
- Choose a Lectrotab control from the following: a basic rocker switch (SAF-S), Oval control with LED trim tab indicators (SETR) or Wireless control with LED trim tab indicators (WTR).
- Install the Lectrotab control of choice per the matching wiring diagram below.

Installing Lectrotab Basic (SAF-S) Rocker Switch Control



SAF-S OR SAB-S
(REAR VIEW W/ TEXT UP)

Use W4-** Interconnect cable
OR

Actuator may be ordered with extended cable i.e.
A-BK-13 = 23ft. (7m)
A-BK-24 = 28 ft. (8.5m)
connecting directly to SAF switch.

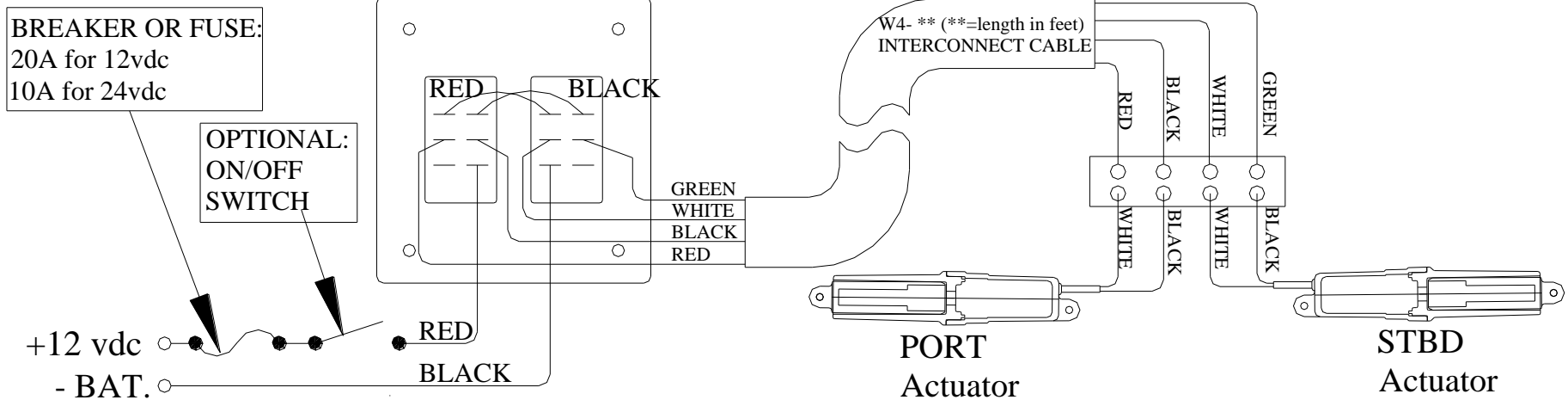



"OVAL" (SETR) Control Installation Diagram

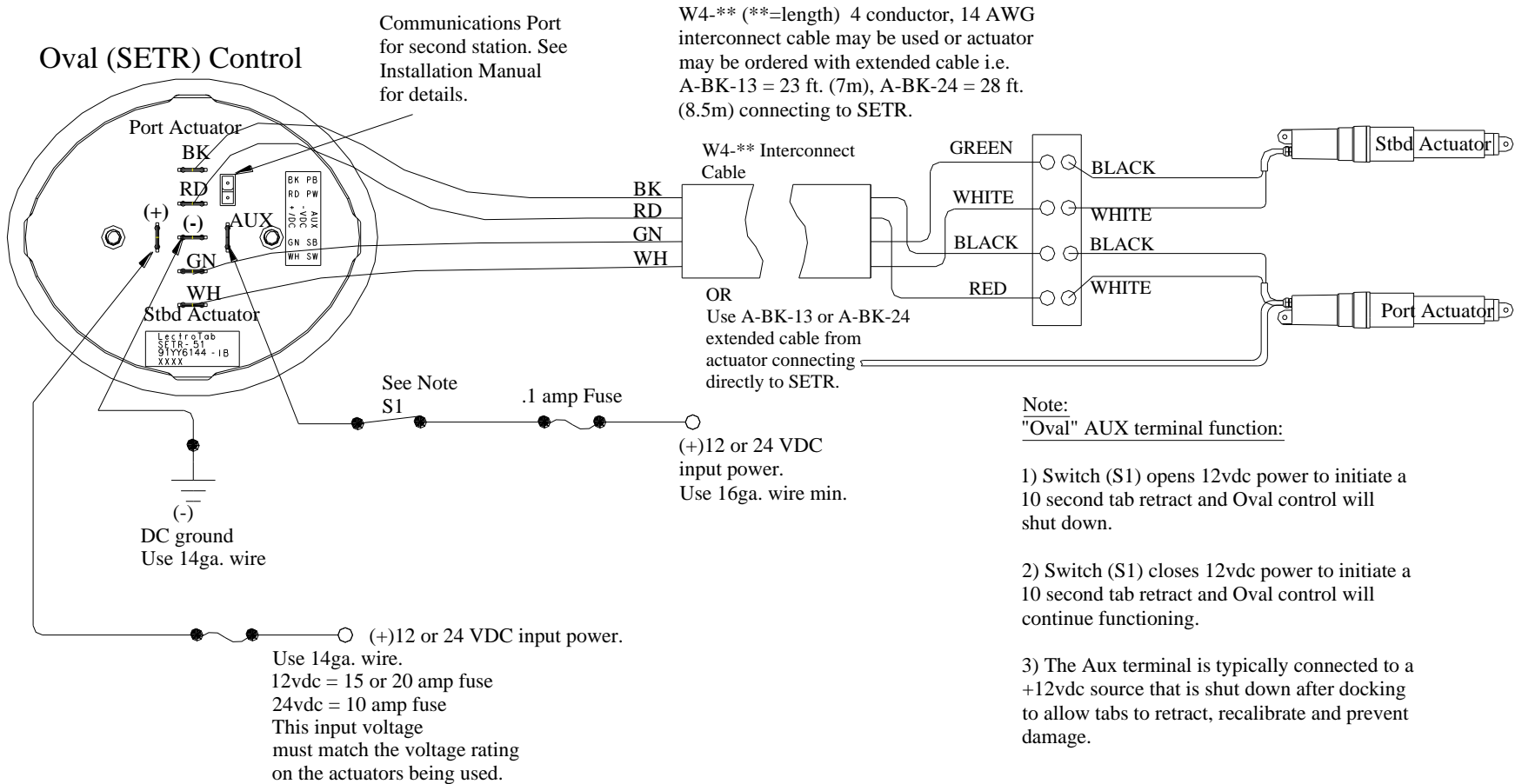



WT Wireless Keypad
(REAR VIEW W/ TEXT UP)

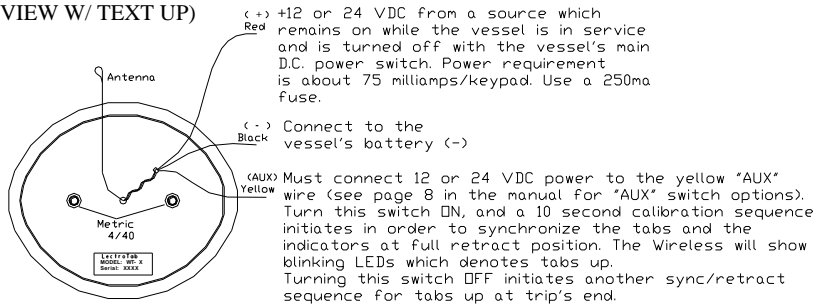

Fully extend antenna vertically and secure with a screw through the loop. Do Not Shorten Antenna Length.

WR Wireless Power Module

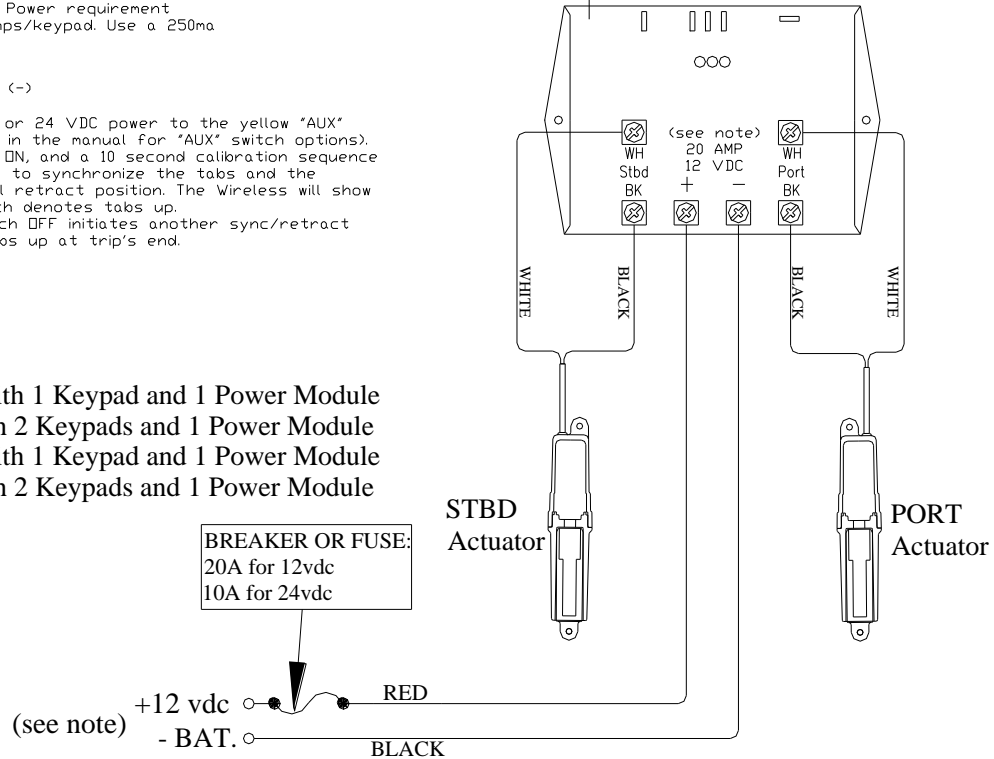

Note:

Wireless Control Models:

- WTR-111 = Single Station 12vdc with 1 Keypad and 1 Power Module
- WTR-121 = Dual Station 12vdc with 2 Keypads and 1 Power Module
- WTR-211 = Single Station 24vdc with 1 Keypad and 1 Power Module
- WTR-221 = Dual Station 24vdc with 2 Keypads and 1 Power Module

Lectrotab
Single Station Wireless Control
Installation Wiring Diagram
6-17-09