



# Trim Tab Actuators HEAVY DUTY



Lectrotab meets the needs of boats operating at high speeds or in rough conditions by offering its heavy duty trim tab actuator. The heavy duty actuator features a reinforced upper mounting boss and a 12 gauge stainless steel upper bracket. Lectrotab heavy duty trim tab actuators are precision-engineered to combine quiet operation with a non-hydraulic, maintenance free design. The unit is corrosion free, ensures very accurate tab positioning, provides maximum lift force, and is totally self-contained for easy installation. The actuator assembly is packaged in a non-metallic permanently sealed housing. No components need to be installed inside the boat. Most importantly, unlike hydraulic trim tabs, there is no oil to leak out. The actuator incorporates a standard or low profile transom mounting bracket. Actuators come in 12 and 24 VDC with 8 second recommended stroke time.

## FEATURES

- Stainless Steel upper mounting bracket
- Reinforced actuator upper mounting boss
- Upper ram seal location cannot be damaged due to fouled ram or barnacle growth
- Utilizes internal pressure equalization system
- Upgrades to most popular hydraulic and electromechanical systems
- Internal brake system prevents unwanted tab movement when under way or backing down
- Quiet operation
- All actuators fully load tested to push 1000 lbs of force
- Non-metallic external structure which cannot corrode and will not deteriorate in the sun or under water

# TRIM TAB ACTUATOR MOUNTING DIMENSIONS

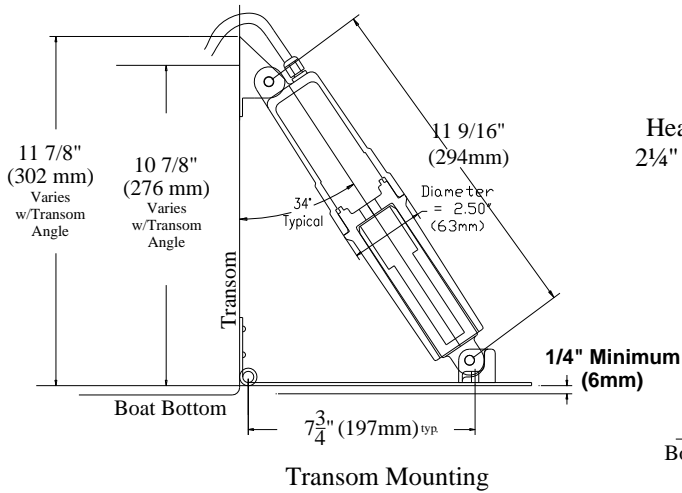

Heavy Duty Actuator  
2 1/4" (57mm) full stroke

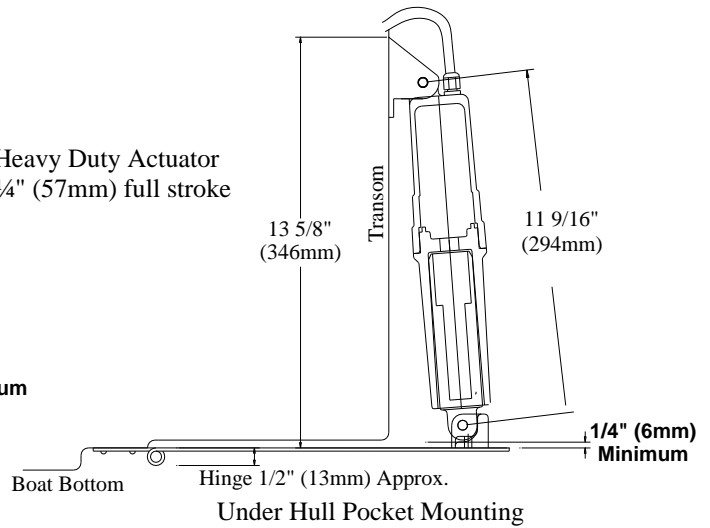

## SPECIFICATIONS

Model	DC Voltage	Stroke Length	Stroke Time	Distance from Bolt to Pin	Vertical Height (Typical Installation Fully Retracted)	Cable Length (Feet/Meter)	Upper Mounting Bracket	Lower Mounting Bracket	Use Actuator with Tabs
A-BK-20	12VDC	2.25" / 57mm	8 sec.	11.5" / 292mm	11.875" / 302mm	6' / 1.8m	Stainless Steel 12 gauge	Standard	All Tabs
A-BK-29	12VDC	2.25" / 57mm	8 sec.	11.5" / 292mm	11.875" / 302mm	23' / 7m	Stainless Steel 12 gauge	Standard	All Tabs
A-BK-41	12VDC	2.25" / 57mm	8 sec.	11.5" / 292mm	11.875" / 302mm	6' / 1.8m	Bolt, Nut & Washer	Bolt, Nut & Washer	TM20X14-8315
A-BK-42	12VDC	2.25" / 57mm	8 sec.	11.5" / 292mm	11.875" / 302mm	23' / 7m	Bolt, Nut & Washer	Bolt, Nut & Washer	TM20X14-8315
B-BK-20	24VDC	2.25" / 57mm	8 sec.	11.5" / 292mm	11.875" / 302mm	6' / 1.8m	Stainless Steel 12 gauge	Standard	All Tabs
B-BK-29	24VDC	2.25" / 57mm	8 sec.	11.5" / 292mm	11.875" / 302mm	23' / 7m	Stainless Steel 12 gauge	Standard	All Tabs
B-BK-41	24VDC	2.25" / 57mm	8 sec.	11.5" / 292mm	11.875" / 302mm	6' / 1.8m	Bolt, Nut & Washer	Bolt, Nut & Washer	TM20X14-8315
B-BK-42	24VDC	2.25" / 57mm	8 sec.	11.5" / 292mm	11.875" / 302mm	23' / 7m	Bolt, Nut & Washer	Bolt, Nut & Washer	TM20X14-8315